

Abmessungen

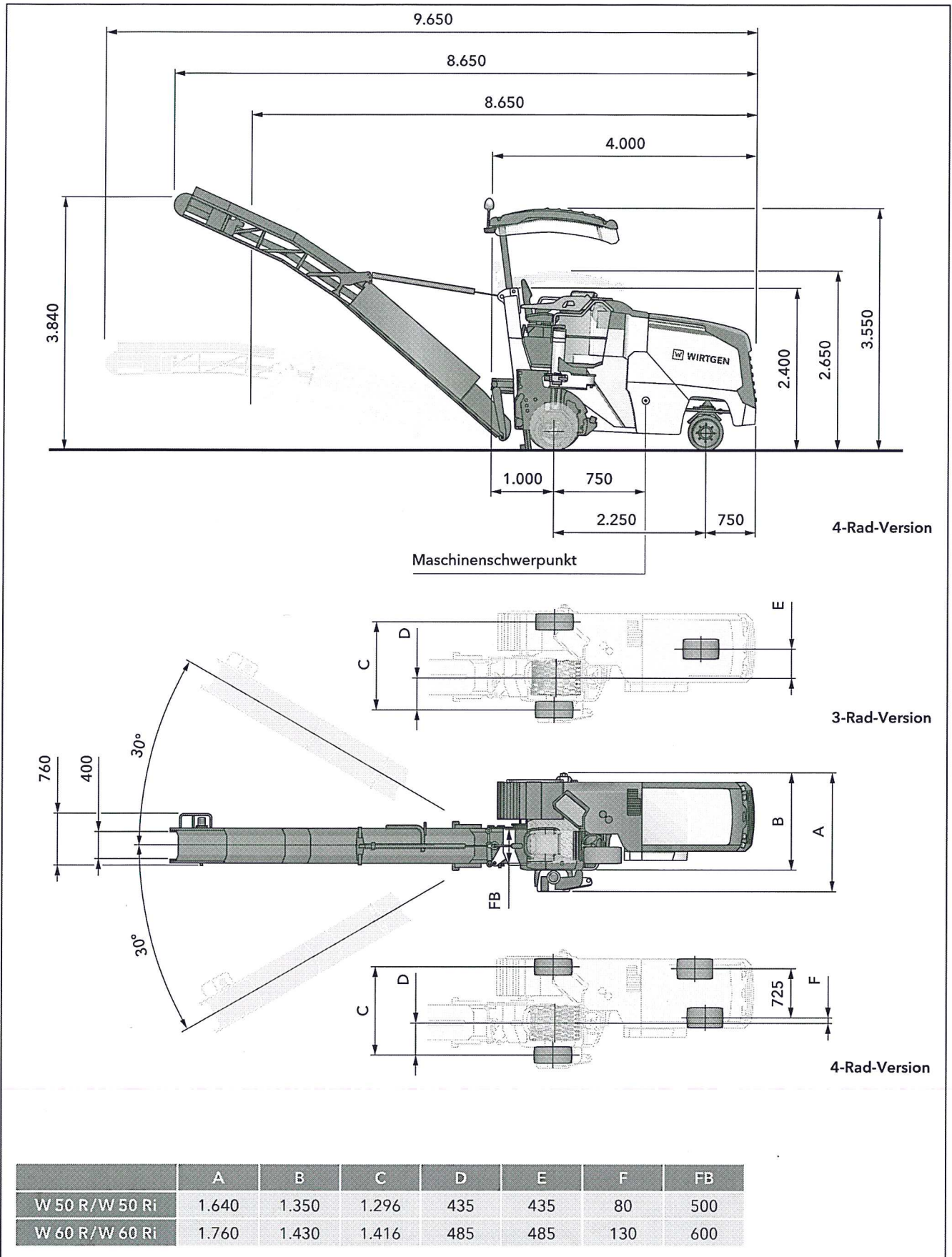

Abmessungen in mm

3-Rad-Version

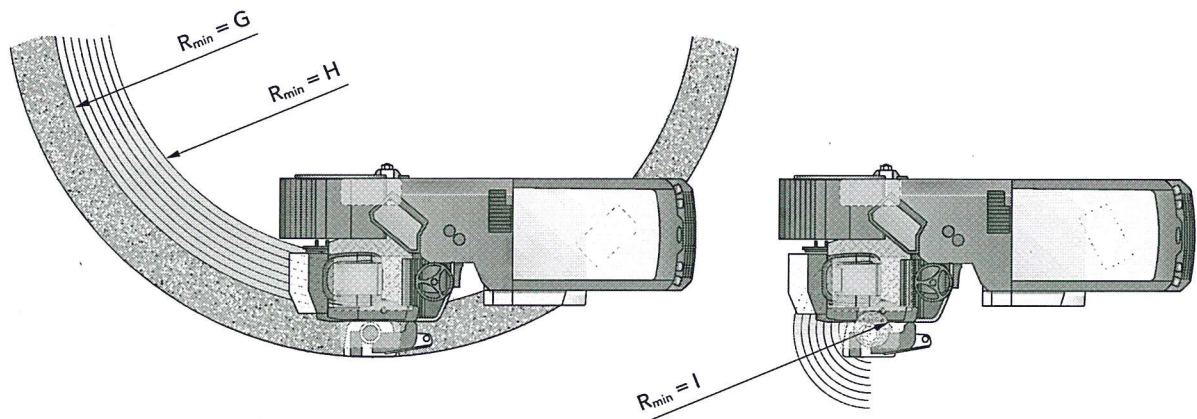

4-Rad-Version

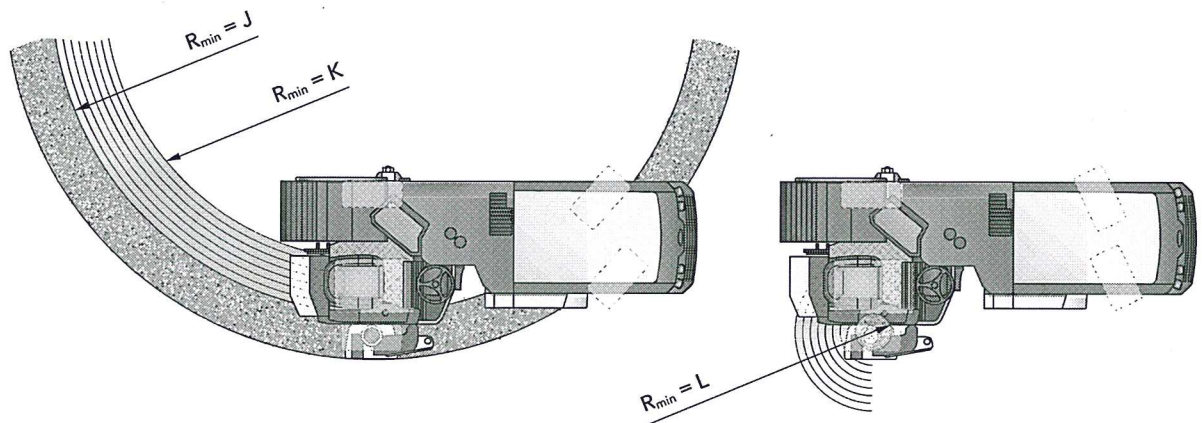

	3-Rad-Version			4-Rad-Version		
	G	H	I	J	K	L
W 50 R/W 50 Ri	2.900	2.400	150	2.350	1.850	150
W 60 R/W 60 Ri	3.000	2.400	50	2.450	1.850	50

Fräskreis, Frästiefe 50 mm, Abmessungen in mm