

Abmessungen

16
17

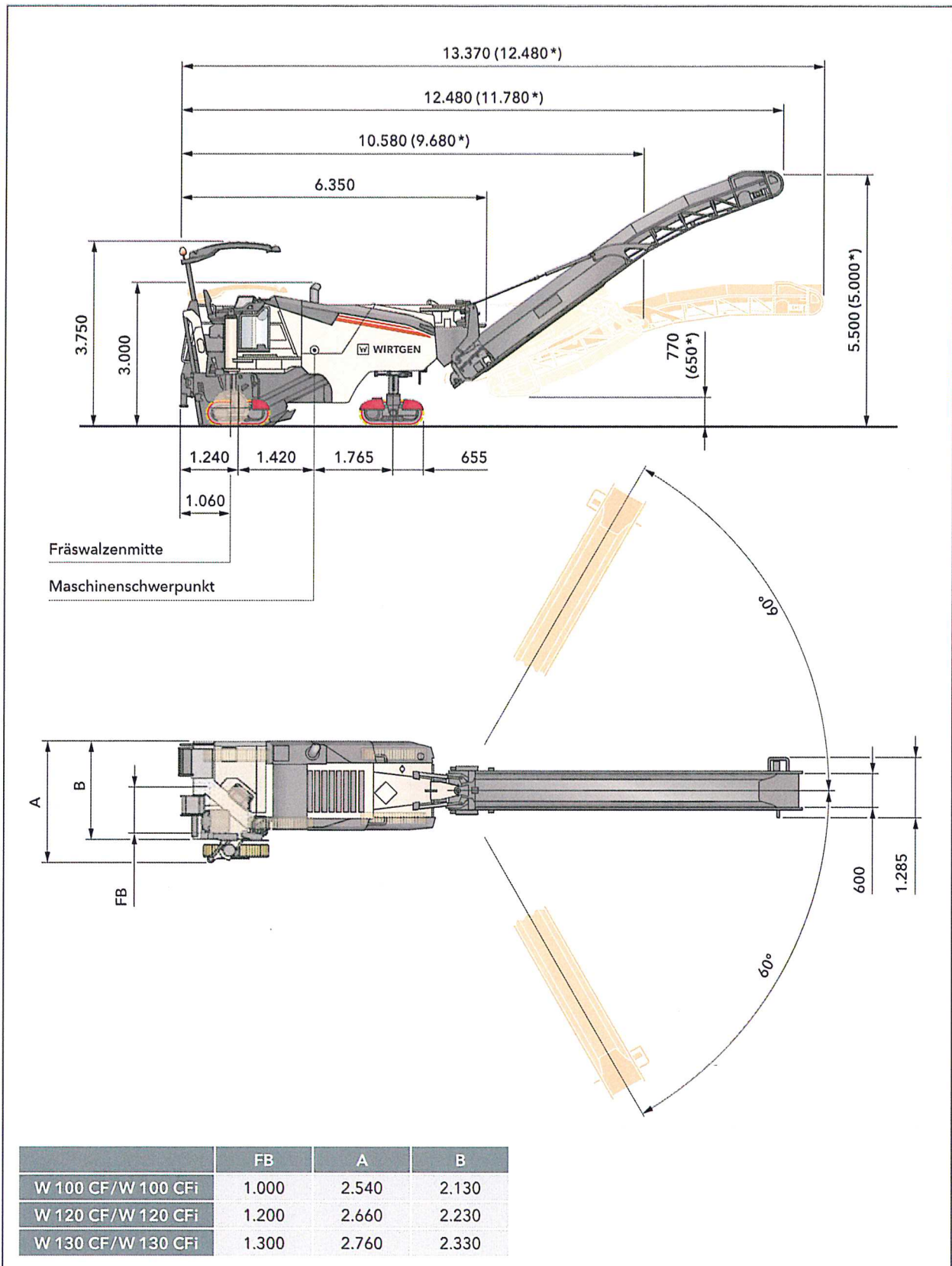

Kaltfräse mit Ketten, Abmessungen in mm

* Faltbares Abwurfband kurz

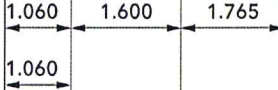
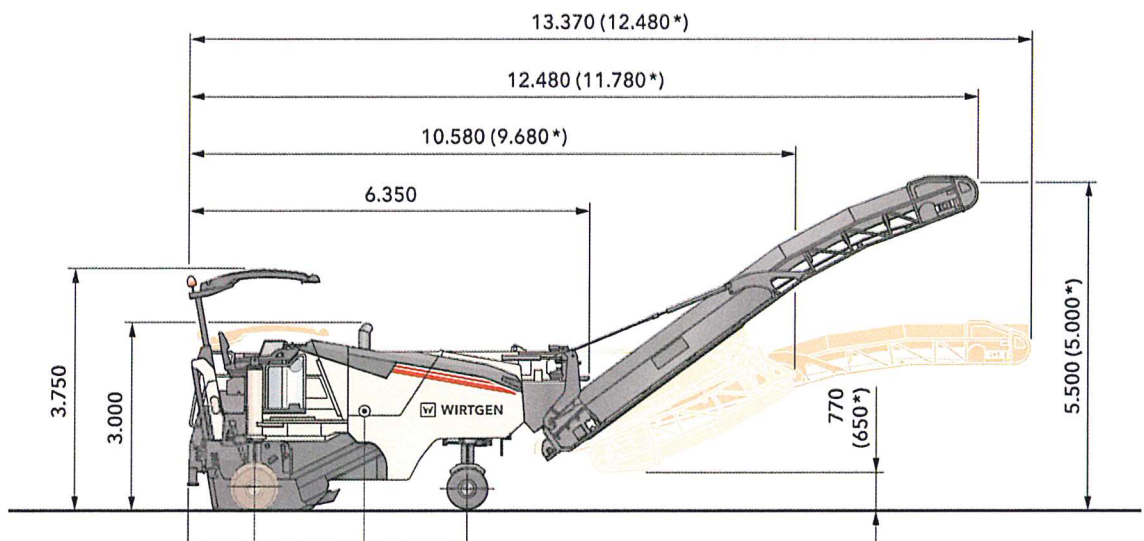

Fräsrollenmitte
 Maschinenschwerpunkt

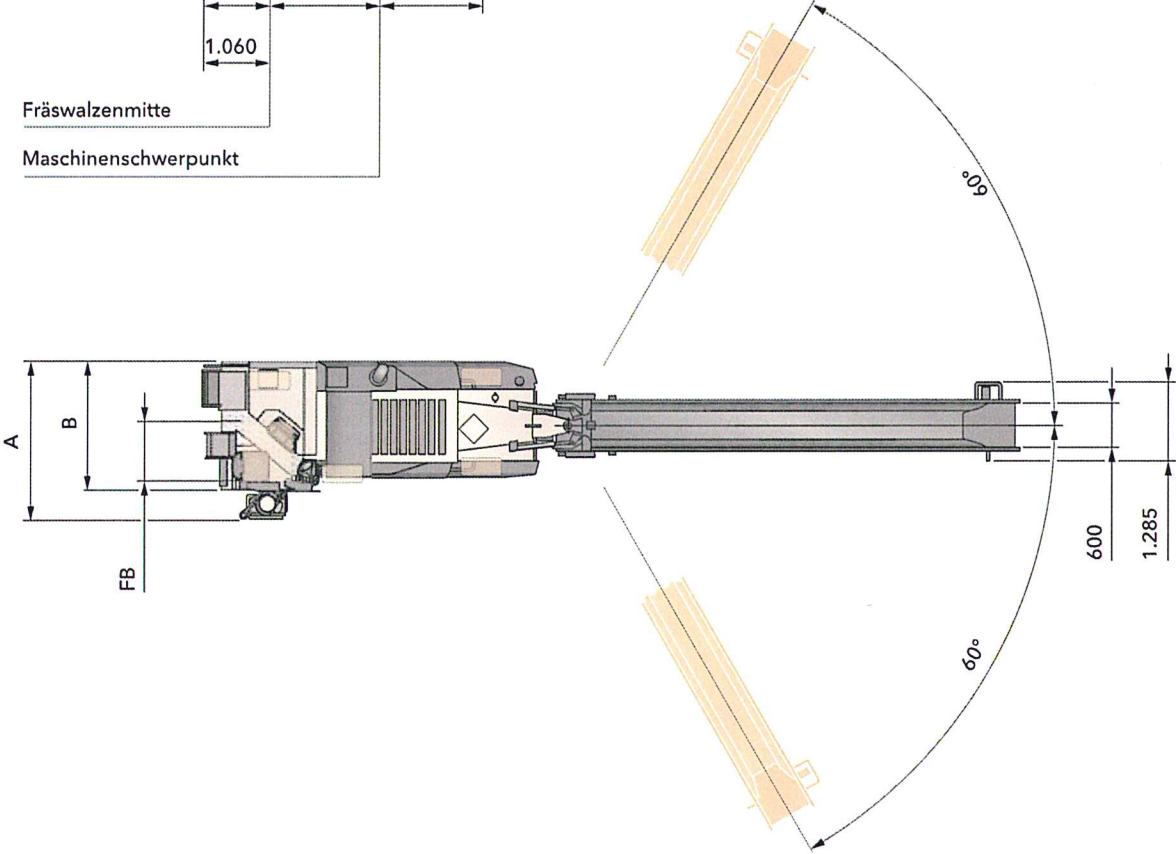

	FB	A	B
W 100 CF/W 100 CFi	1.000	2.540	2.130
W 120 CF/W 120 CFi	1.200	2.660	2.230
W 130 CF/W 130 CFi	1.300	2.760	2.330

Kaltfräse mit Rädern, Abmessungen in mm
 * Faltbares Abwurfband kurz

Abmessungen

18
19

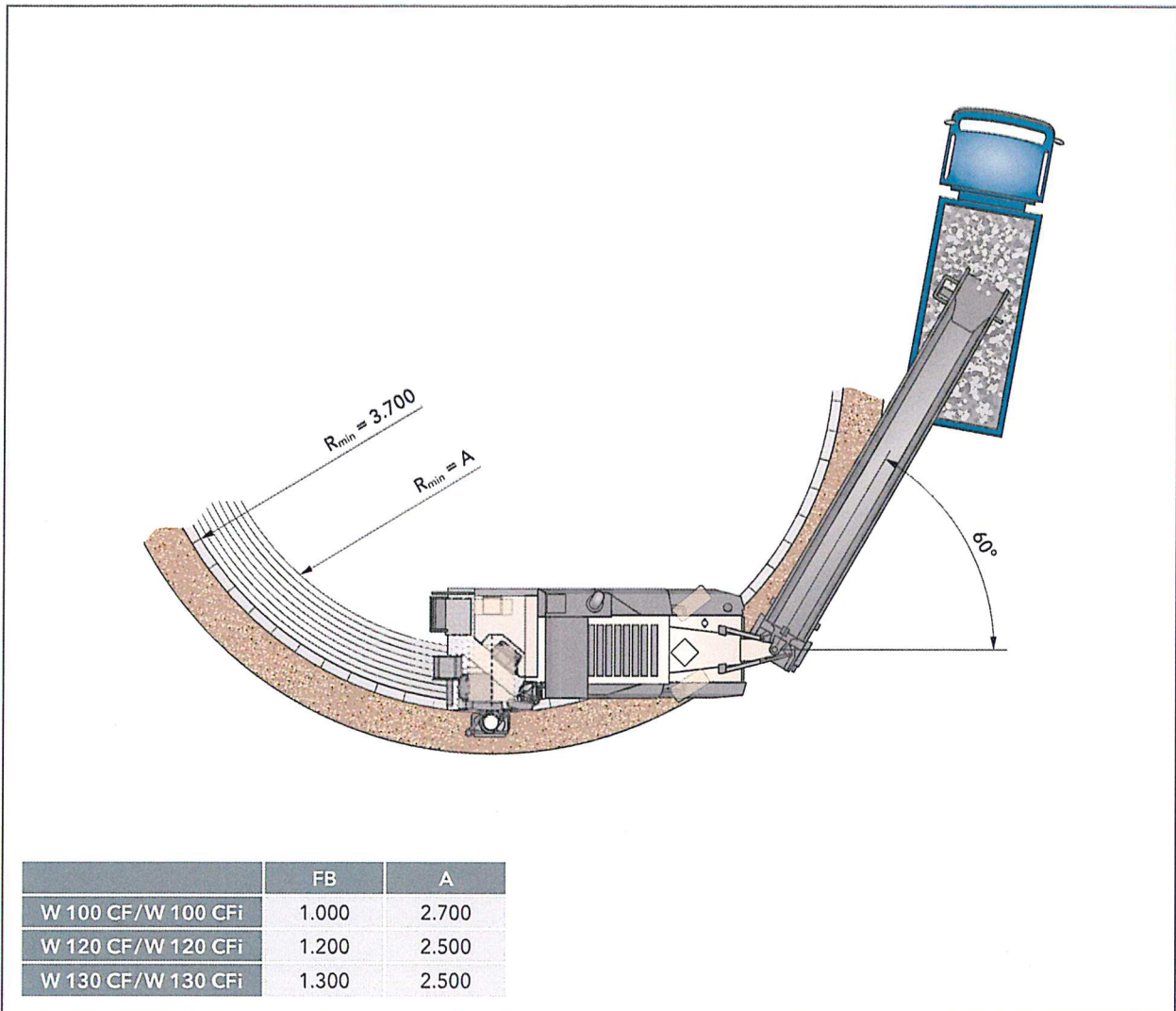

Fräskreis, Frästiefe 150 mm, Abmessungen in mm